

Wizard CompSpec C2 Assembly Instructions



Parts Needed

Truck assembly from previous steps

Bag C

- (1) part# ott-tko10-010 Servo Mount x1
- (2) part# ott-tko10-006 Track Bar Mount x1
- (3) part# ott-tko10-079 M3 x 0.5 x 8mm button head screw x5
- (4) part# ott-tko10-080 M3 x 0.5 x 10mm button head screw x1
- (5) part# ott-tko10-082 M3 x 0.5 x 14mm button head screw x1
- (6) part# ott-tko10-093 M3 nylock nut x1

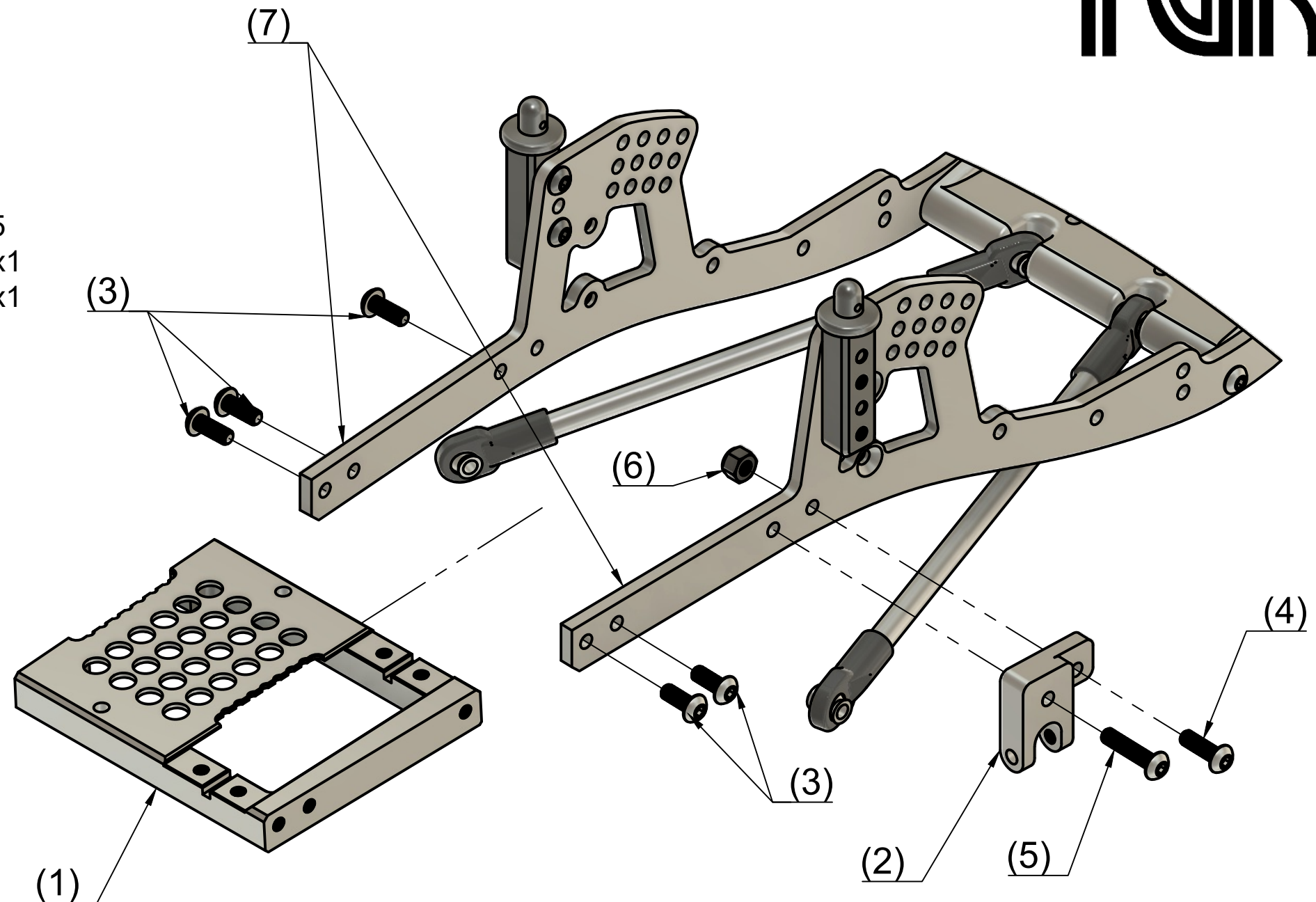

Step 6

blue threadlock is recommended on all threads

Insert Servo Mount (1) in between front of chassis rails (7)

Loosely insert 5 M3 x 0.5 x 8mm screws (3) through chassis rails (7) and into Servo Mount (1) then tighten completely

Insert M3 x 0.5 x 14mm screw (5) through Track Bar Mount (2) and loosely tighten into Servo Mount (1)

Insert M3 x 0.5 x 10mm screw (4) through Track Bar Mount (2) and chassis rail (7) and tighten into M3 nylock nut (6)

Fully tighten M3 x 0.5 x 14mm screw (5)

