

# Wizard CompSpec C2 Assembly Instructions



## Parts Needed

### Bag F

- (1) part# ott-tko10-018 Body Mount Brackets from chassis x2
- (2) part# ott-tko10-003 Body Mount x2
- (3) part# ott-tko10-080 M3 x 0.5 x 10mm button head screw x4

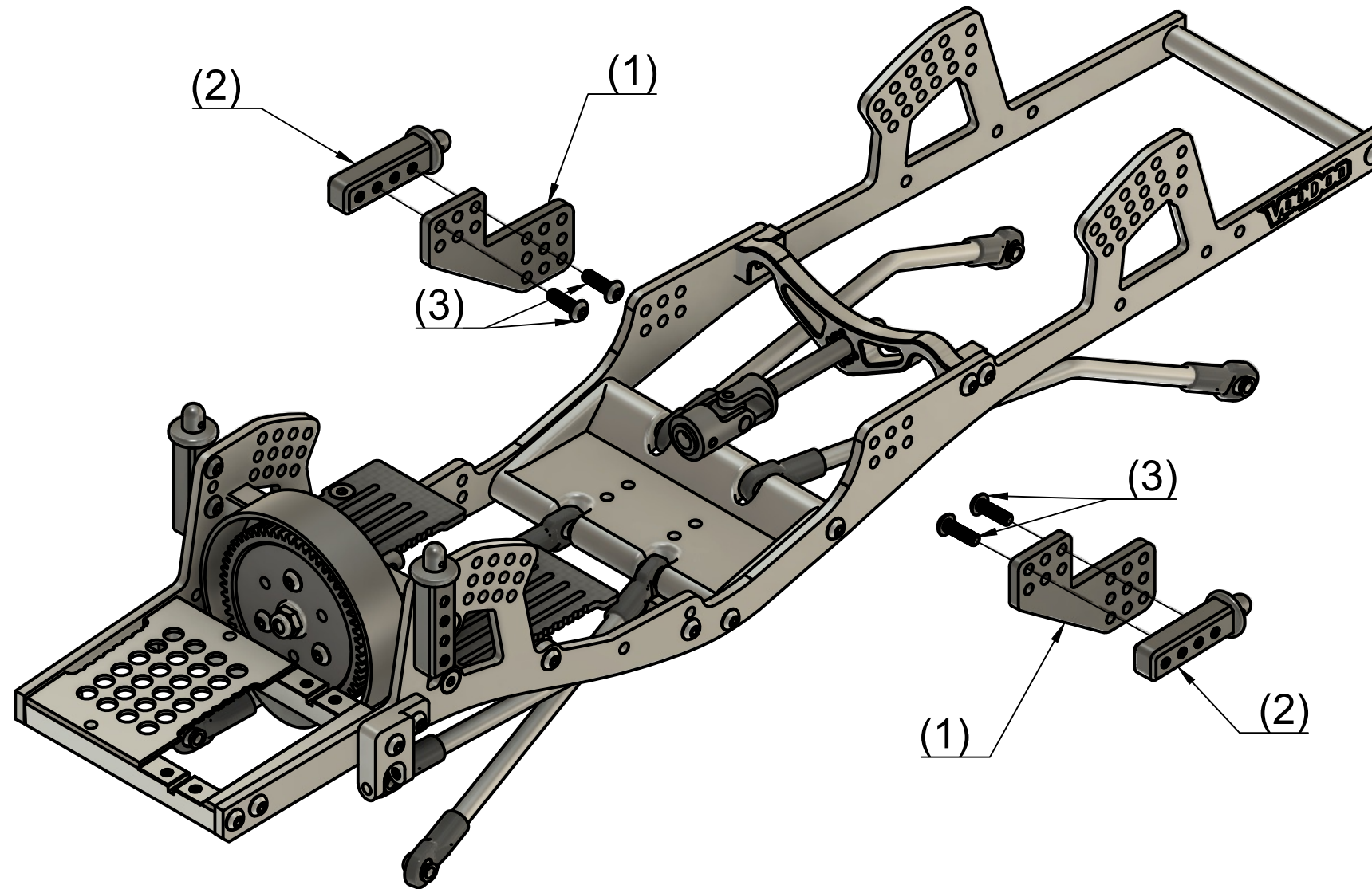

### Step 25

Insert 2 M3 x 0.5 x 10mm button head screws (3) through Body Mount Brackets (1) and tighten into Body Mount (2)

