

Parts Needed

Truck assembly from previous steps

Bag F

- (1) part# ott-tko10-084 M3 x 0.5 x 18mm button head screw x2
- (2) part# ott-tko10-080 M3 x 0.5 x 10mm button head screw x2
- (3) part# ott-tko10-093 M3 nylock nut x4
- (4) part# ott-tko10-022 Rear Upper Link x2

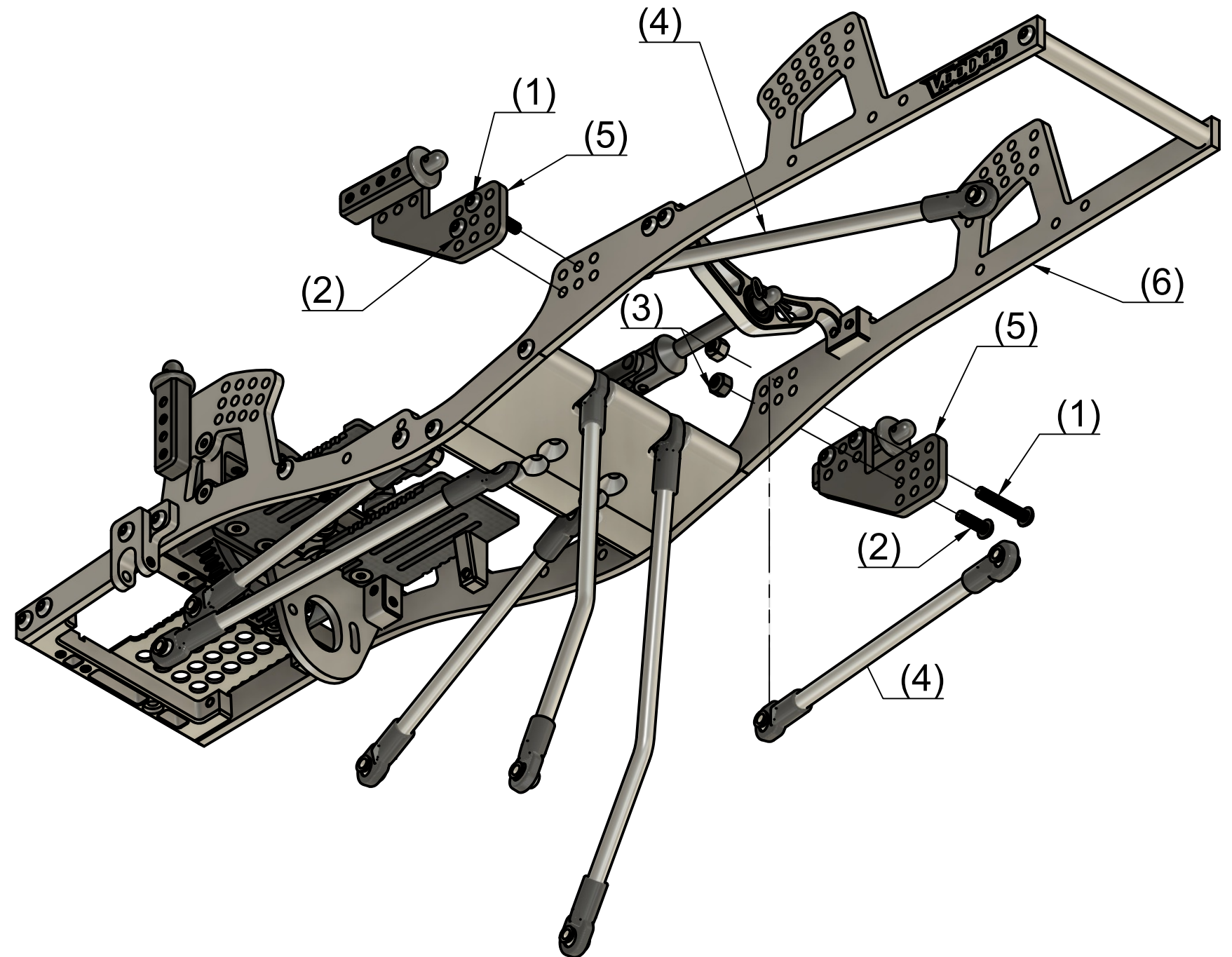

Step 26

Insert M3 x0.5 x 10mm button head screw (2) through Body Mount Bracket (5) and chassis rail (6) then install M3 nylock nut (3) to M3 x 0.5 x 10mm button head screw (2) and loosely tighten

Step 27

Insert M3 x 0.5 x 18mm button head screw (1) through Body Mount Bracket (5) and chassis rail (6) then install Rear Upper Link (4) on to M3 X 0.5 X 18mm button head screw (1) then install M3 nylock nut (3) onto M3 x 0.5 x 18mm button head screw and fully tighten all screws from steps 26 and 27