

Wizard CompSpec C2 Assembly Instructions



Parts Needed

Truck assembly and Forward Motor Mount assembly from previous steps

Bag E

(1) part# ott-tko10-088 M3 x 0.5 x 8mm flat head screw x4

(2) part# ott-tko10-079 M3 x 0.5 x 8mm button head screw x2

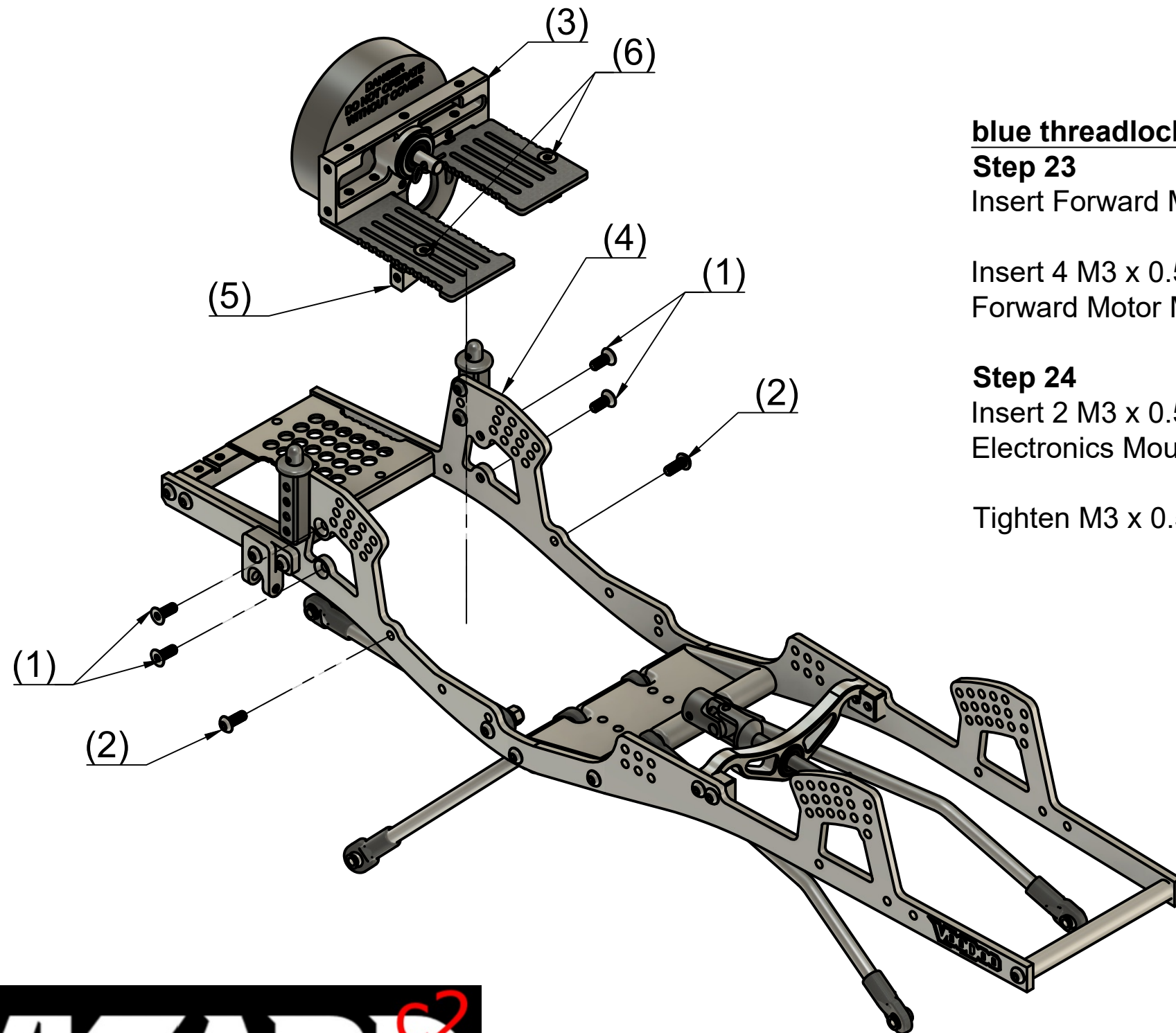

blue threadlock is recommended on all threads

Step 23

Insert Forward Motor Mount Assembly (3) into chassis (4)

Insert 4 M3 x 0.5 x 8mm flat head screws (1) through chassis and into Forward Motor Mount (3) and loosely tighten

Step 24

Insert 2 M3 x 0.5 x 8mm button head screws (2) through chassis into Electronics Mount Brackets (5) and tighten completely

Tighten M3 x 0.5 x 6mm flat head screws (6) from step 23