

Wizard CompSpec C2 Assembly Instructions



Parts Needed

Truck assembly from previous steps

Bag G

- (1) part# ott-cs-90-s Voodoo Comp Shock 90mm x4
- (2) part# ott-tko10-083 M3 x 0.5 x 16mm button head screw x4
- (3) part# ott-tko10-093 M3 nylock nut x4
- (4) part# ott-tko10-101 2mm Spacer x4

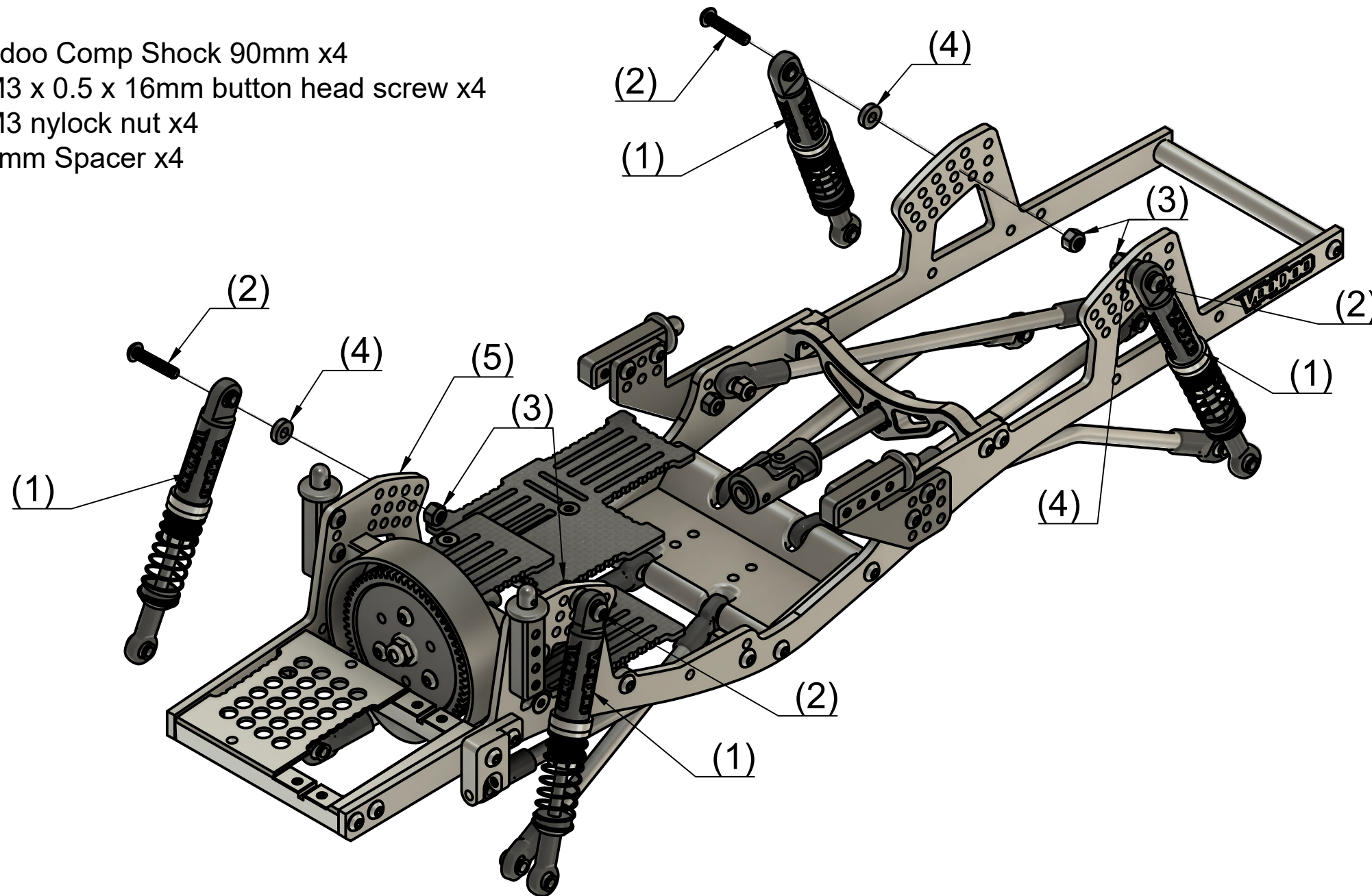

Step 28

Insert M3 x 0.5 x 16mm button head screw (2) through shock (1) at upper cap then through 2mm spacer (4) and chassis (5) then attach M3 nylock nut (3) and tighten

Process is the same for all shocks

